

# **SOUND ANCHOR ASSEMBLY INSTRUCTIONS FOR MOTORIZED STUDIO MONITOR STAND WITH SELECTABLE START HEIGHT**

Thank you for purchasing Sound Anchor Motorized Monitor Stands. These stands were specifically developed with the needs of the audio professional in mind. They will deliver a high of performance for many years to come.

1. Install one spike into each insert on the bottom of the stand so that about 1/2" of thread is left protruding from the stand.
2. Install washers and jam nuts. (**FINGER TIGHTEN JAM NUTS USE NO TOOLS**).
3. Mount the platform assembly using 7/16-14 socket head cap screws and hardened washers. Lightly tighten using provided 3/8" hex key.
4. Place stand in the intended use location.
5. Level the stand using the spikes so that the upright is perpendicular to the floor.
6. Tighten jam nuts using 9/16 wrench.

## **INSTALLING MOTORS**

1. Position the motors as shown on page 3 of these instructions so that the four holes on the motor mounting tabs line up with the four M6 threaded holes in the motor base.
2. Fasten the stand base to the motor base using four M x 20 button head cap screws with flat-washers . **FINGER TIGHTEN ONLY**
3. Tighten the screws with the provided hex wrench until they are just snug. **TAKE CARE TO NOT OVERTIGHTEN**

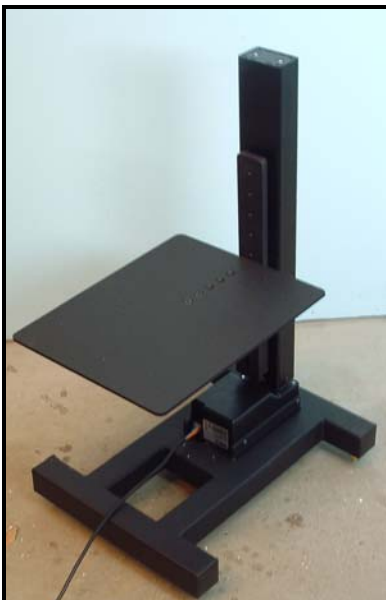

## INSTALLING MOTORS

1. Position the motors as shown on page 3 of these instructions so that the four holes on the motor mounting tabs line up with the four M6 threaded holes in the motor base.
- 2.** Fasten the stand base to the motor base using four M x 20 button head cap screws with flat-washers . **FINGER TIGHTEN ONLY**
3. Tighten the screws with the provided hex wrench until they are just snug. **TAKE CARE TO NOT OVERTIGHTEN**

## INSTALLING THE SPEAKER PLATFORMS

1. Install the speaker mounting arms to the upright fasten with 5/16-18 x 1" socket head cap screws . NOTE THAT THERE ARE TWO SET-UP OPTIONS see figures one and two. Note that you may use any of the threaded holes on the mounting bar but it is preferable to have one or two blank holes between them. These holes are for coarse height adjustment the slots in the arm allow fine adjustment.
2. Fasten the speaker platform to the arm using two 1/4-20 x 5/8 flathead socket cap screws.

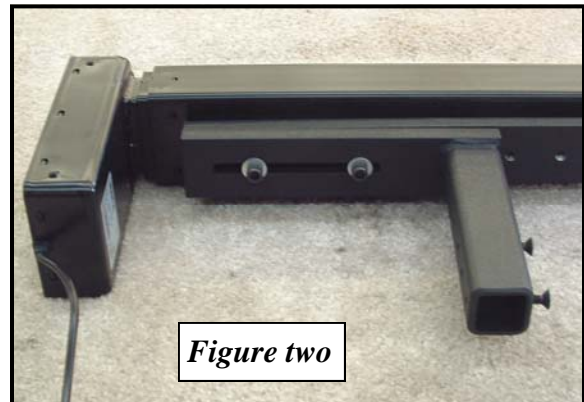
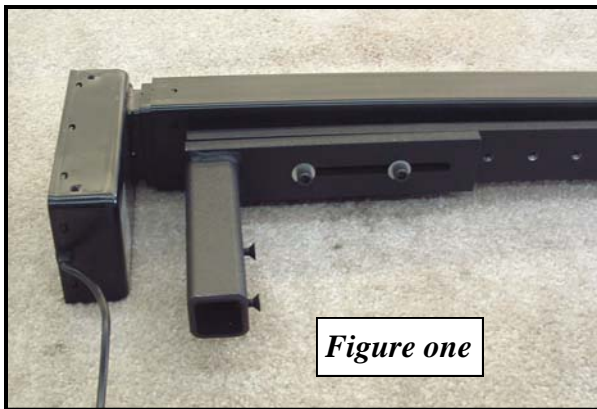

## SETTING UP STANDS

1. Place stand in the intended use location.
2. Level the stand using the spikes so that the upright is perpendicular to the floor.
3. Tighten jam nuts using a 9/16 or 14mm open end wrench.
4. Adjust the platform height to the height that you will want your speakers when they are in the down position and tighten 5/16-18 x 1" Screws using provided hex key.

## PUTTING YOUR STANDS TO MOTION

- 1.** Connect all wiring as shown on schematic on page 4. **NOTE IF YOU HAVE MORE THAN ONE MOTOR ALL MOTORS MUST BE CONNECTED BEFORE POWER UP OR NONE WILL WORK.**
2. After everything is connected together and plugged in hold the down button for 45 seconds. This is an initial start procedure that syncs the motor with the controller.
3. Remove the plastic film from the bluedots then place one bluedot on each corner of the speaker platform.
4. Place the speaker on top of the platform. Take care that the speaker baffle is forward of the front edge of the speaker platform so that there are no diffractions.
5. You may need to adjust the platform height in order to get the desired start height.

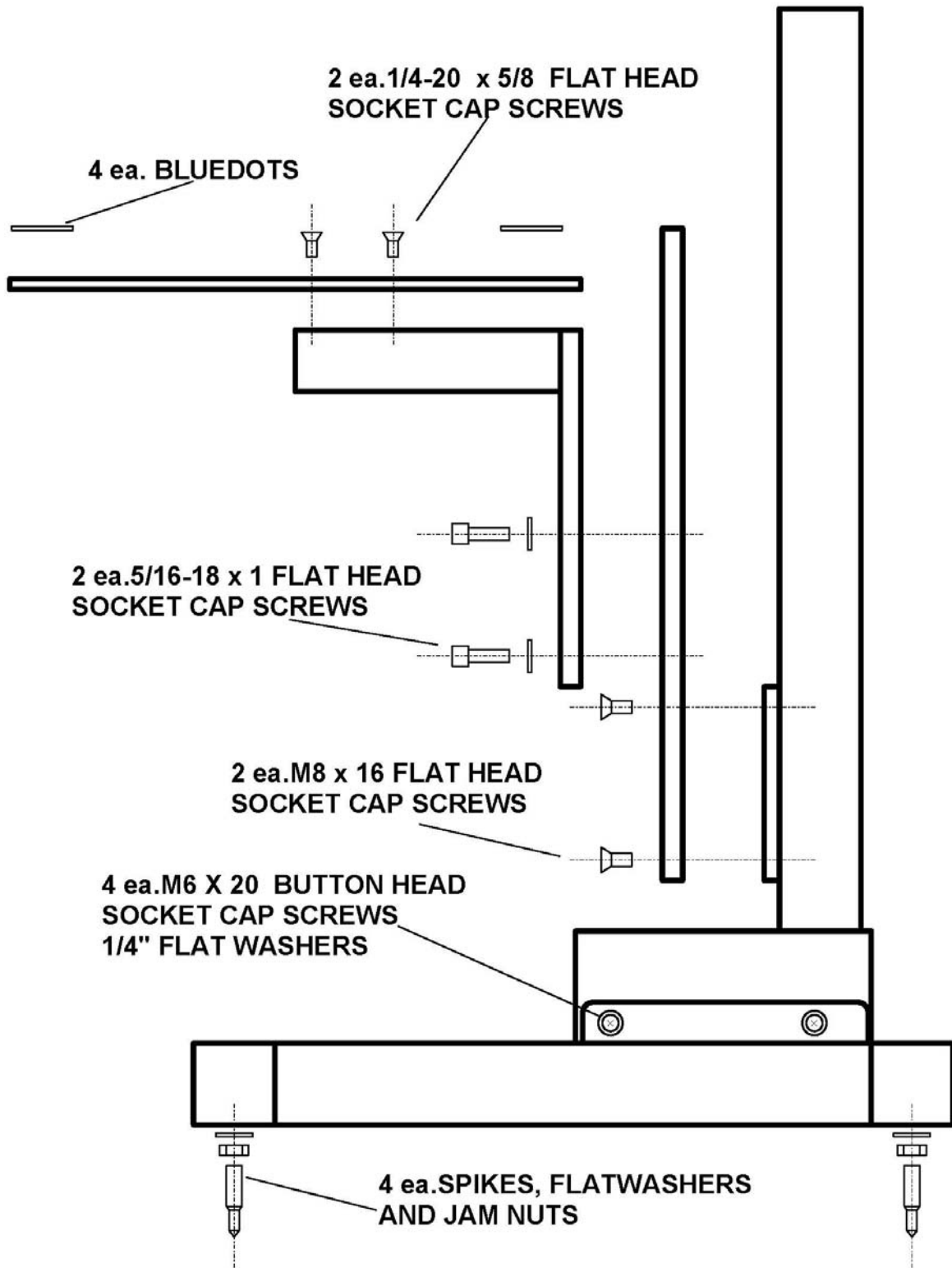

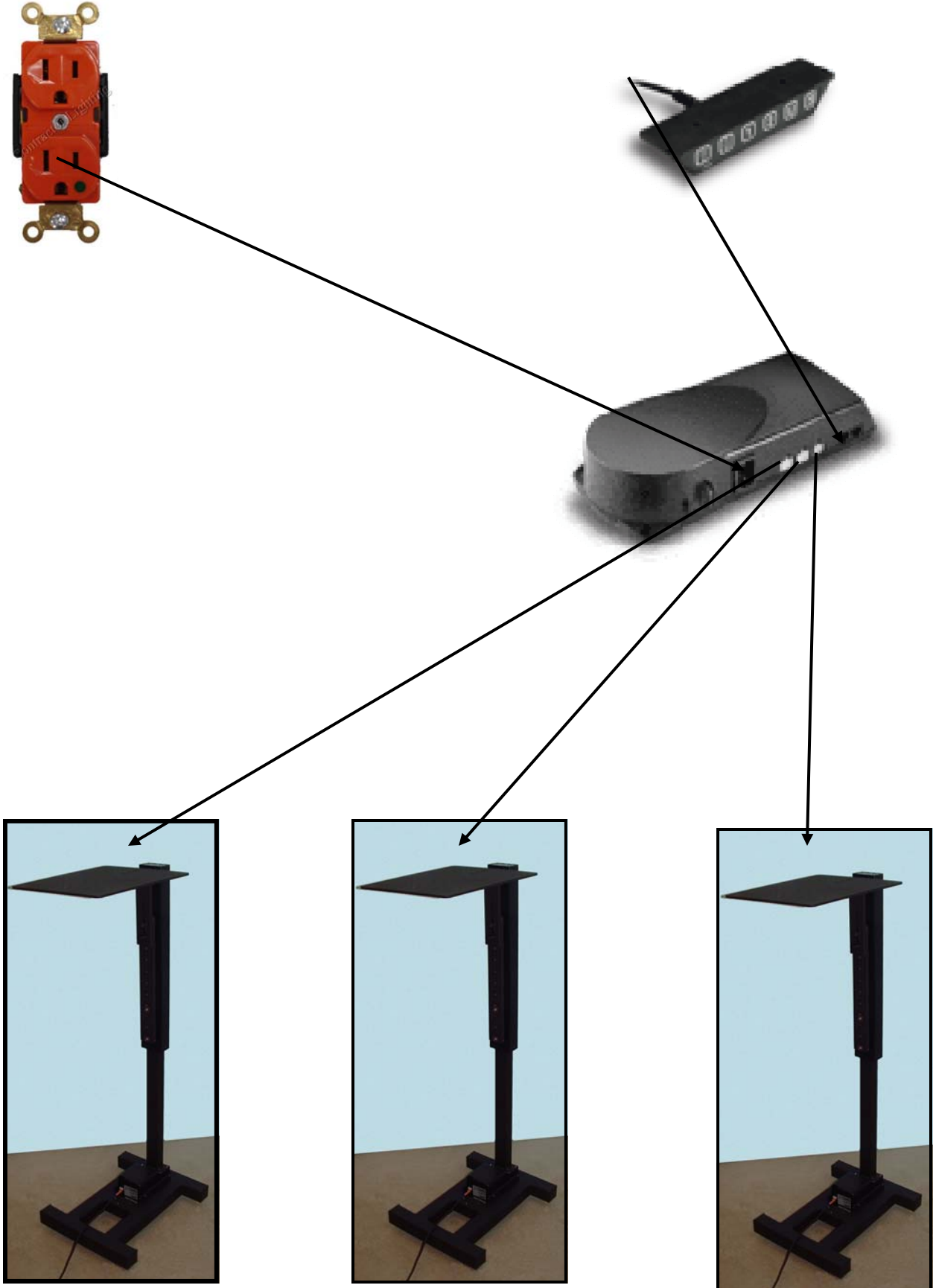
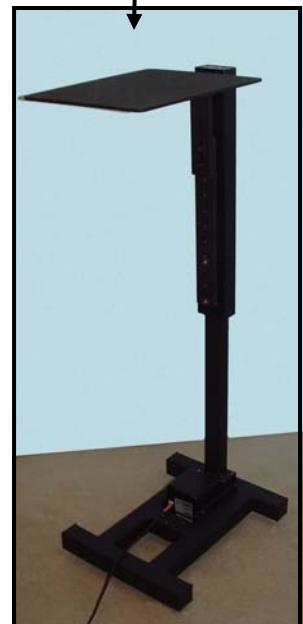
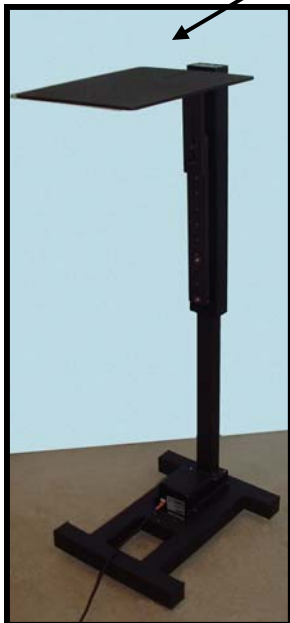
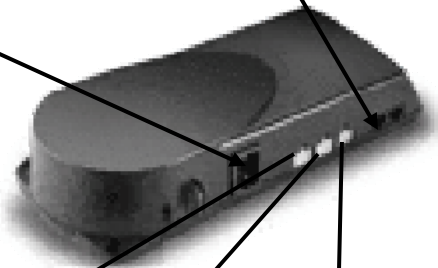

### INVENTORY:

1. 1 Lift Motor
2. 1 Base weldment
3. 1 Speaker Platform
4. 1 Speaker platform arm weldment
5. 1 Speaker Adjuster Bar
6. 4 Bluedots
7. 2 1/4-20 x 5/8 flat head soc head cap screw
8. 2 M8 x 20 flat head soc head cap screw
9. 4 M6 x 20 button head soc head cap screw
10. 4 3/8 in. flat washer
11. 4 3/8-16 jam nut
12. 4 3/8-16 spikes
13. 2 5/16-18 x 1 socket head cap screw
14. 2 5/16 flat washer
15. 4 1/4 flat washer

### ELECTRICAL PARTS:

13. 1 Control Box (may be shared)
14. 1 Remote Switch (1 per control Box)
15. 1 Motor control Cable (1 per Motor)
16. 1 Power Cable (1 per Control Box)

### TOOLS

17. 1 6mm Hex Key
18. 1 3/16 Hex Key
19. 1 5/32 Hex Key

If any of these parts are missing please contact Sound Anchors at (407) 724-1237.

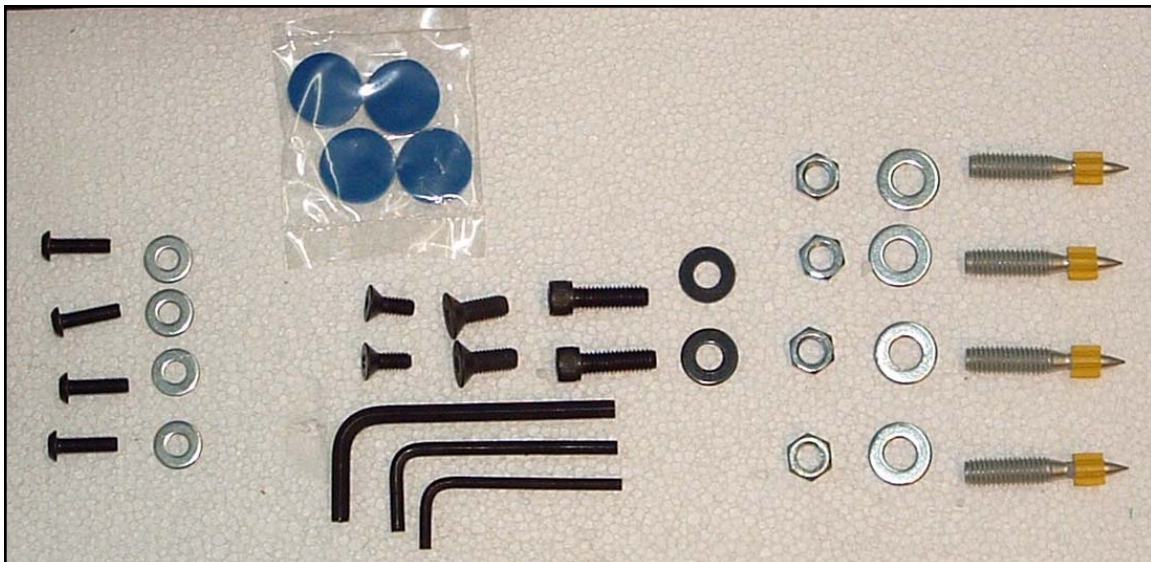

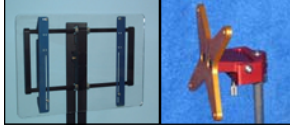

# SOUND ANCHOR



## STUDIO SOLUTIONS made in USA

### **ADJUSTABLE MONITOR STANDS**

Adjustable height and tilt. Designed to support near field monitors above the meter bridge. Support your monitors properly and improve performance. The best near field solution for your studio.

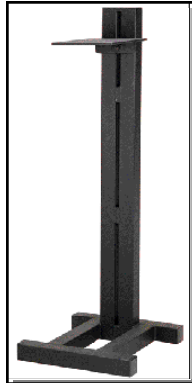

### **LARGE ADJUSTABLE MONITOR STANDS**

These adjustable stands allow height and tilt adjustment for your midfield or main monitors. Custom made to support any large speaker. Support your large studio monitors where they sound best.



### **MOTORIZED ADJUSTABLE MONITOR STANDS**

Motorized remote controlled adjustable height speaker stands that can be adjusted from the engineer's chair. Designed so that you can hide your near field monitors when not in use.



### **DIGITAL AUDIO WORKSTATION STAND**

Heavy duty Remote DAW Workstation stand models for single or dual monitors and keyboard. Ideal for digital editing or computer based recording systems.

### **ADJUSTABLE LCD STAND**

Solid stable adjustable stand for mounting your VESA compliant LCD computer monitor in free space. This stand will support monitors up to 30".



### **ADJUSTABLE PLASMA LCD STAND**

Large adjustable stands designed to support large flat screen monitors in free space. Redmount large monitor mount. 3 different base sizes, 3 different heights available.



**SOUND ANCHORS INC**  
**2835 KIRBY CIRCLE**  
**PALM BAY, FL. 32905**  
**PHONE/FAX 321 724 1237**  
**[www.soundanchors.com](http://www.soundanchors.com) [info@soundanchors.com](mailto:info@soundanchors.com)**